

**ALPHA**  
**MICROSYSTEMS**  
RIGHT. FROM THE START.

**ALPHA**  
**MICROSYSTEMS**  
RIGHT. FROM THE START.

**ALPHA**  
**MICROSYSTEMS**  
RIGHT. FROM THE START.

**ALPHA**  
**MICROSYSTEMS**  
RIGHT. FROM THE START.

**ALPHA**  
**MICROSYSTEMS**  
RIGHT. FROM THE START.

**ALPHA**  
**MICROSYSTEMS**  
RIGHT. FROM THE START.

**ALPHA**  
**MICROSYSTEMS**  
RIGHT. FROM THE START.

**ALPHA**  
**MICROSYSTEMS**  
RIGHT. FROM THE START.

**ALPHA**  
**MICROSYSTEMS**  
RIGHT. FROM THE START.

**ALPHA**  
**MICROSYSTEMS**  
RIGHT. FROM THE START.

**ALPHA**  
**MICROSYSTEMS**  
RIGHT. FROM THE START.

**ALPHA**  
**MICROSYSTEMS**  
RIGHT. FROM THE START.

**ALPHA**  
**MICROSYSTEMS**  
RIGHT. FROM THE START.

**ALPHA**  
**MICROSYSTEMS**  
RIGHT. FROM THE START.

**ALPHA**  
**MICROSYSTEMS**  
RIGHT. FROM THE START.

**ALPHA**  
**MICROSYSTEMS**  
RIGHT. FROM THE START.

**ALPHA**  
**MICROSYSTEMS**  
RIGHT. FROM THE START.

**ALPHA**  
**MICROSYSTEMS**  
RIGHT. FROM THE START.

**ALPHA**  
**MICROSYSTEMS**  
RIGHT. FROM THE START.

**ALPHA**  
**MICROSYSTEMS**  
RIGHT. FROM THE START.

**ALPHA**  
**MICROSYSTEMS**  
RIGHT. FROM THE START.

For Authorized  
Service Personnel Only:  
AM-6060  
Service Manual

**FIRST EDITION:** April 1998

To re-order this document, request part number DSS-10594-00

**FCC Notice**

This equipment has been tested and found to comply with the limits for a Class A digital device, pursuant to Part 15 of the FCC Rules. These limits are designed to provide reasonable protection against harmful interference when the equipment is operated in a commercial environment. This equipment generates, uses and can radiate radio frequency energy and, if not installed and used in accordance with the instruction manual, may cause harmful interference to radio communications. Operation of this equipment in a residential area is likely to cause harmful interference in which case the user will be required to correct the interference at his own expense.

**Canadian Department of Communications Compliance Statement**

This equipment does not exceed Class A limits per radio noise emissions for digital apparatus set out in the Radio Interference Regulations of the Canadian Department of Communications. Operation in a residential area may cause unacceptable interference to radio and TV reception requiring the owner or operator to take whatever steps are necessary to correct the interference.

**Avis de Conformité aux Normes du Ministère des Communications du Canada**

Cet équipement ne dépasse pas les limites de Classe A d'émission de bruits radioélectriques pour les appareils numériques tels que prescrites par le Règlement sur le brouillage radioélectrique établi par le ministère des Communications du Canada. L'exploitation faite en milieu résidentiel peut entraîner le brouillage des réceptions radio et télé, ce qui obligerait le propriétaire ou l'opérateur à prendre les dispositions nécessaires pour en éliminer les causes.

**Battery Warning**

CAUTION: Danger of explosion if battery is incorrectly replaced. Replace only with the same or equivalent type recommended by the manufacturer. Discard used batteries according to the manufacturer's instructions.

ATTENTION: Il y a danger d'explosion s'il y a un remplacement incorrect de la batterie. Remplacer uniquement avec une batterie du même type ou d'un type recommandé par le constructeur. Mettre au rebut les batteries usagées conformément aux instructions du fabricant.

For AM-3500-E100, -E200, -E300, -E400, -E500 and AM-990-01 systems replace battery with Panasonic or Ray-O-Vac BR2325 only. For AM-3500-E550, AM-3500-6000, and AM-990-04 systems, replace batteries with Panasonic or Ray-O-Vac BR1225 only. Use of other batteries may present a risk of fire or explosion. Replacement batteries may be ordered from your authorized Alpha Micro reseller.

**Safety Warning**

This computer contains no user-configurable components that require opening the computer case. Because the power supply in this computer is capable of outputting high current levels hazardous to your safety, the computer case should only be opened by an authorized service technician.

Cet ordinateur ne contient aucune pièce configurable par l'utilisateur qui nécessite l'ouverture du boîtier. L'alimentation de cet ordinateur peut produire des niveaux de tensions dangereux, le boîtier ne devrait donc être ouvert que par un technicien autorisé.

**SOFTWARE SECURITY DEVICE IDENTIFICATION NUMBER: \_\_\_\_\_**

The Alpha Micro Software Security Device (SSD) is a customized integrated circuit that personalizes the computer, providing identity verification for it. Certain Alpha Micro and non-Alpha Micro software may require that your computer contain an SSD in order to run software that has been customized to run only on your computer.

Please enter the identification of your SSD above. The SSD identification number should be on your computer ID label under "SSD Serial No." (Another way of finding the number is to look at the SSD itself. The SSD is located in an integrated circuit location on the CPU board; its identification number is printed on the SSD itself.) Software vendors may ask you for the SSD number if they are customizing software to run only on your computer.

This document may contain references to products covered under the following U.S. Patent Number(s): 4,530,048

ALPHA MICROSYSTEMS  
2722 S. Fairview Street  
P. O. Box 25059  
Santa Ana, CA 92704

# Table of Contents

INTRODUCTION.....	1
ACCESSING YOUR COMPUTER.....	1
ELECTRONIC EQUIPMENT HANDLING PRECAUTIONS.....	2
BOARD VERSIONS AND COMPATIBILITY.....	3
REPLACING THE AM-301-10 BOARD.....	3
HARDWARE CONFIGURABLE OPTIONS .....	4
Printed Circuit Board Configuration.....	4
Remote Reset Capability.....	7
Replacing the Time and Date Battery .....	7
SSD and PROM Chip Removal .....	8
AM-966-10 CONNECTIONS.....	9
UPGRADING AM-6060 ON-BOARD MEMORY .....	10
Removing Memory SIMMs .....	10
Installing the External Cache SIMM.....	11
Installing Memory SIMMs.....	12
Setting Memory Jumpers .....	13
PERIPHERAL MOUNTING.....	14
ADDITIONAL DOCUMENTATION .....	16

# Table of Figures

Figure 1: Chassis Top Cover Screws .....	1
Figure 2: Chassis Top Cover Removal .....	2
Figure 3: Static Protection Wrist Strap .....	3
Figure 4: AM-301-10 Board Configuration.....	4
Figure 5: AM-176 Board Configuration .....	6
Figure 6: AM-301-10 Backup Battery Removal.....	8
Figure 7: SSD Chip Removal Tools.....	9
Figure 8: AM-966-10 Board Layout.....	9
Figure 9: AM-176 SIMM Module Installation .....	11
Figure 10: JP4 Memory Jumpers .....	13
Figure 11: Peripheral Bay Positions.....	15

## INTRODUCTION



The instructions in this document are intended only for authorized service personnel. AM-6060 computers contain a high-output power supply, which produces current levels high enough to make it unsafe for unauthorized persons to perform work inside the chassis.

This document describes the following procedures and topics for the AM-6060 computer:

- Removing your computer's cover and electronic equipment handling precautions
- Board versions and compatibility
- Replacing the AM-301-10 board
- Configuration options for the AM-301-10 and AM-176 boards
- Connections to the AM-966 front panel display
- Installing memory
- Peripheral installation

## ACCESSING YOUR COMPUTER

When adding additional equipment or servicing your computer, you will need to remove your computer's top cover. The top cover is held in place with four Phillips-head screws on the computer's rear panel. To remove the top cover, remove all four screws from the locations indicated in Figure 1. Once the screws have been removed, you can slide back and remove the top cover, as shown in Figure 2.

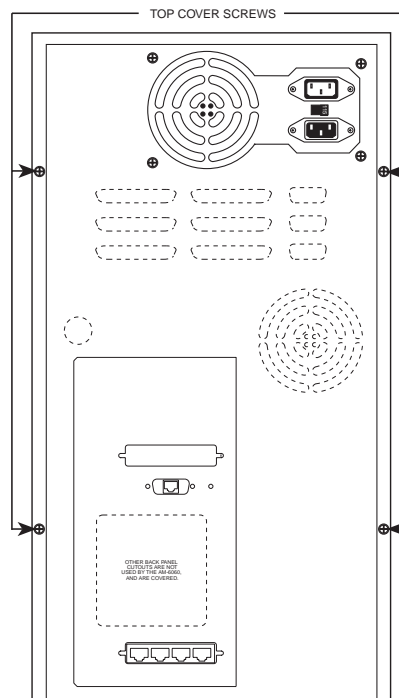

*Figure 1: Chassis Top Cover Screws*

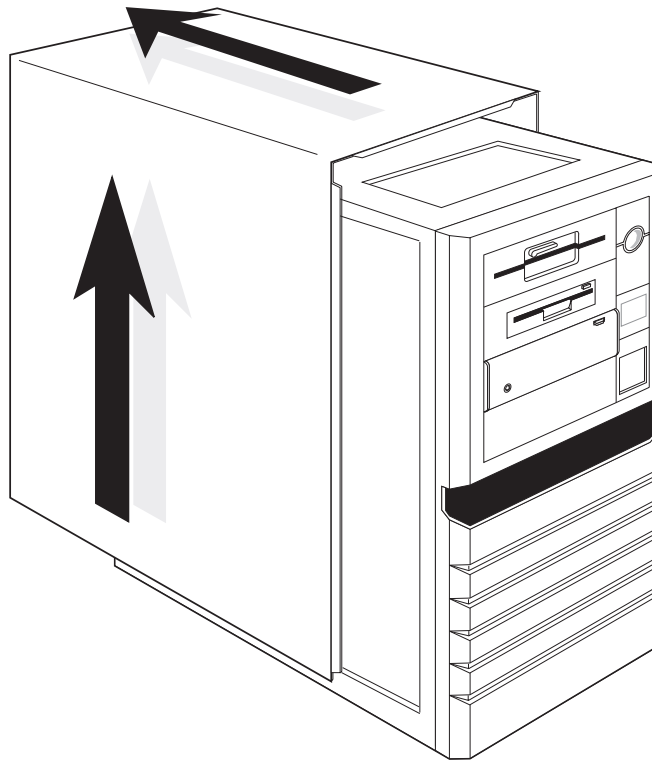

*Figure 2: Chassis Top Cover Removal*

## **ELECTRONIC EQUIPMENT HANDLING PRECAUTIONS**

With the AC power cord unplugged and the top cover removed, the components inside your computer are vulnerable to damage caused by static discharge. Your body and clothing can store an electrical charge that can damage or destroy unprotected electronic components. Before handling any computer hardware, make sure your work area is properly protected against static discharge. There are a number of commercially available static protection devices, like the wrist strap shown in Figure 3, designed specifically to protect your equipment from harmful static discharge.

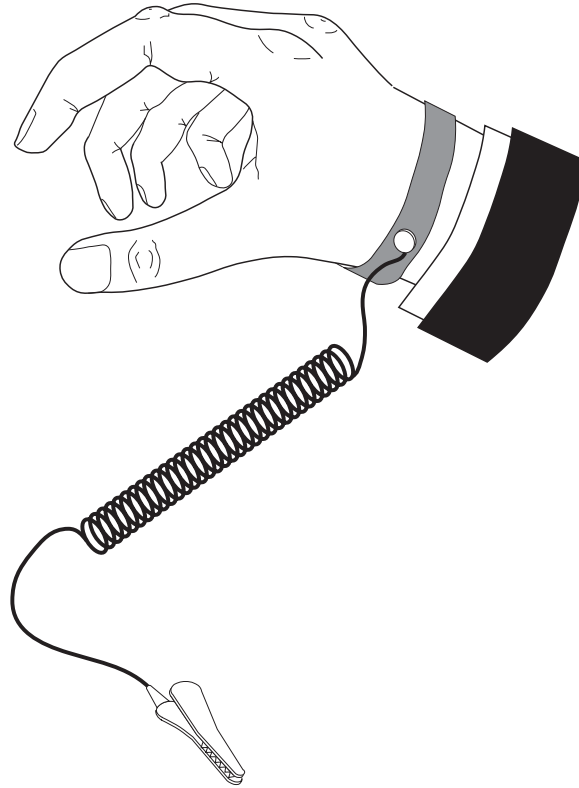

*Figure 3: Static Protection Wrist Strap*

## BOARD VERSIONS AND COMPATIBILITY

Only certain versions of the AM-176 CPU board can be used in the AM-6060. Specifically, the AM-176 must be Rev. C04 or later, with boot PROMs (DWB-00176-10) Rev. B00 or later.

The front panel display board in the AM-6060 must be the AM-966-10. No other front panel display board is supported.

## REPLACING THE AM-301-10 BOARD

The AM-301-10 board plugs directly into the AM-176 board; it is not attached by cables. If you need to remove and replace it, there are connectors on the AM-301-10 at locations P1, P2, and P3 which plug into the AM-176 at P4, P6, and J6.

When connecting the AM-301-10, be sure to align the connectors properly. To ensure proper alignment, the P1 connector has a keying bump on it. Plug this connector in carefully, *without forcing*, and the bump will ensure proper alignment of all connectors.

## HARDWARE CONFIGURABLE OPTIONS

The following sections summarize the configuration options available to let you tailor your hardware to your needs. These options require access to the main circuit boards inside the computer, and should be performed only by qualified technical personnel. Contact your VAR if you need assistance.

### Printed Circuit Board Configuration

The next few sections contain configuration information for the AM-301-10 and AM-176 boards

#### AM-301-10 Board Configuration

The AM-301-10 board supports the four serial ports in the AM-6060. It also contains your computer's SSD chip, real-time clock, and other I/O related circuitry.

Figure 4 shows the AM-301-10 board configured as shipped by Alpha Micro. (The illustration does not show all components on the board.) Field-configurable jumpers are noted on the figure and described after it. All other jumpers should be left in their factory configured positions.

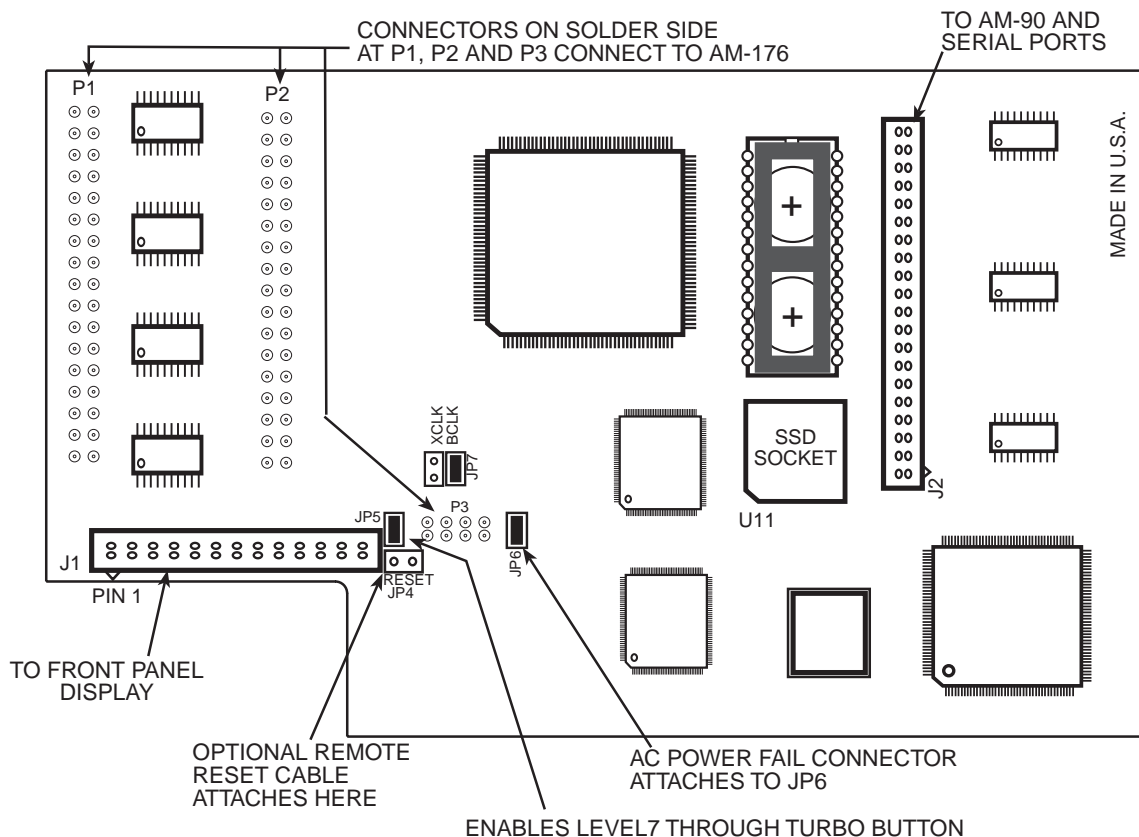

**Figure 4: AM-301-10 Board Configuration**

The only two field-configurable jumpers are:

- JP4: the optional remote reset cable attaches to the left pin here. See page 7.
- JP5: when installed, pressing the Turbo button on the front panel places the computer into the Level7 diagnostic state. See the *LEVEL7 User's Guide* for instructions on how to proceed when the computer is in Level7.

In addition, the AC power fail connector attaches to JP6. Make sure the red wire connects to the top pin (as shown in Figure 4) and the black wire to the bottom.

### AM-176 Board Configuration

The AM-176 board contains a 68060 CPU chip, one 50-pin SCSI connector and one 68-pin Wide SCSI connector, one boot PROM, a high-performance Ethernet interface, and all of your computer's on-board memory. Your AM-176 board has been factory tested and shipped with its configuration jumpers set in their standard default positions. Only two areas on the board may require you to change jumper settings:

- Memory size select (JP4)
- Enabling or disabling the supply of SCSI bus termination voltage (JP3)—default set at enabled.

The AM-176 board is shown in Figure 5 with all of its jumpers in their default positions. (The illustration does not show all components on the board.)

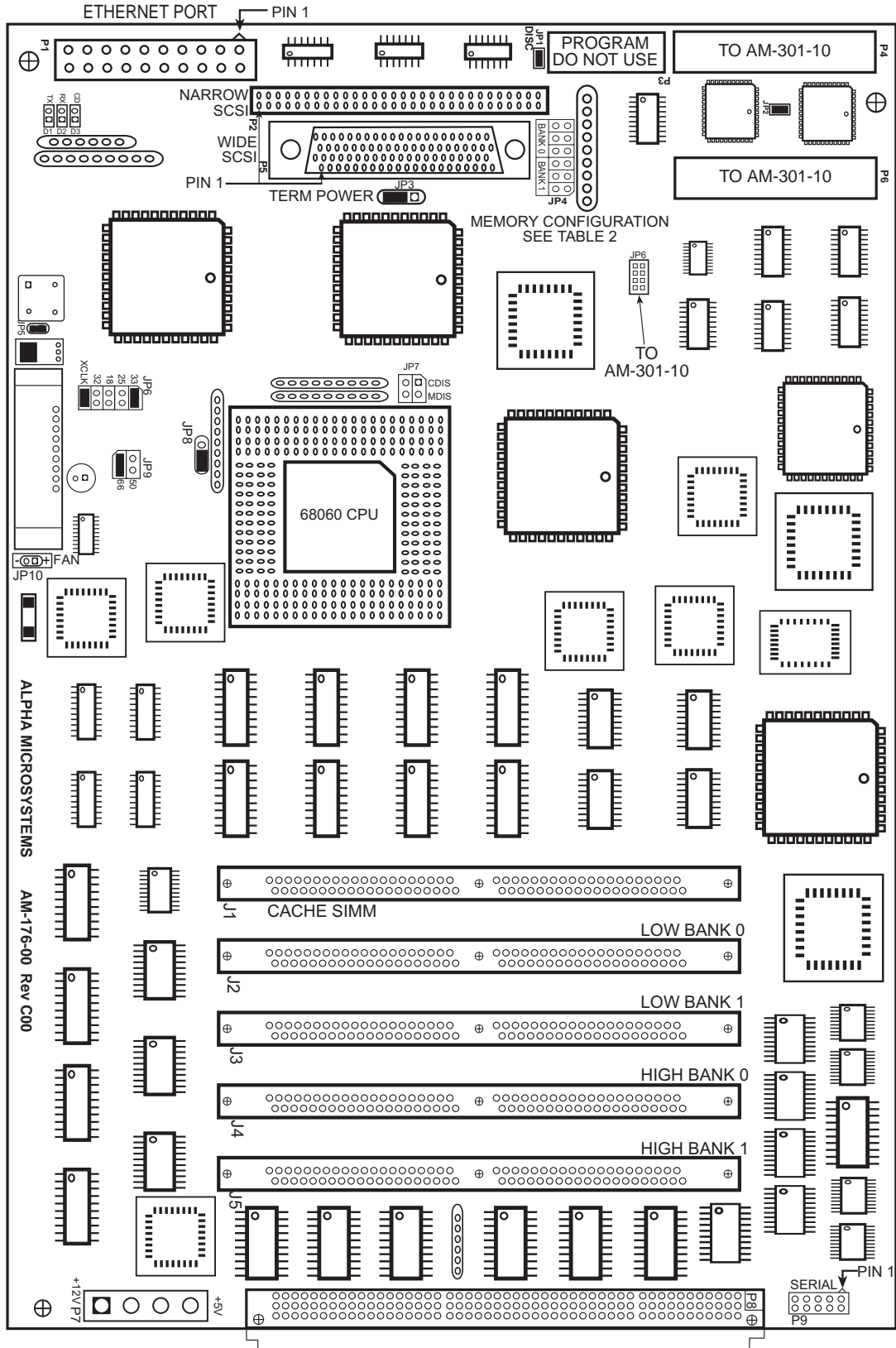

Figure 5: AM-176 Board Configuration

## Remote Reset Capability

The AM-301-10 board has an option to enable the computer's remote hardware reset, using a special cable from Alpha Microsystems, part number DWB-10323-00. To enable remote reset:

1. Connect one end of the cable to JP4 (to the pin nearer J1) on the AM-301-10 board.
2. The other of the cable contains a DB-9F connector; attach this to any unused cutout on the back panel. You will probably have to remove a cover plate on the back panel to do so.
3. Run a cable from the DB-9F connector on the back panel to the location from which you want to be able to reset the computer. The far end of the cable should consist of a push-button switch between pin 1 and pin 7 (signal ground).

Once you've enabled remote reset, you can reset the computer by activating the push-button switch.

## Replacing the Time and Date Battery



When replacing the backup batteries, always be sure to turn off power to the system first! **DO NOT** replace the batteries with the power on! As always when opening your computer chassis, take proper precautions against electrostatic discharge, which can seriously damage system components.

The AM-301-10 board uses two 3-volt lithium batteries (BR-1225) to power its time/date circuit. The batteries are about the size of a dime (1.2 cm), and are secured side-by-side in a plastic holder at location U10, as shown in Figures 4 and 6.

The batteries need to be replaced when the front status display shows B1 or B0. You must replace both batteries at the same time. For battery replacement, please follow these steps:



Before turning off your computer, make a note of the current CMOS settings. Removing the batteries will erase all CMOS data.

1. Insert a knife with a thin blade (such as a small scribe or Xacto™ knife) from the top, down through the square hole between the right edge of the battery and the plastic holder's top piece. (The right side is the side toward the connector at J2.)
2. Gently pry the right side of the battery so it slides to the left and pushes against the left side spring contacts.
3. As you slide the battery to the left and it clears the plastic top hole, pry the right edge of the battery upward and out through the hole in the top. The battery will typically "pop" up and out.

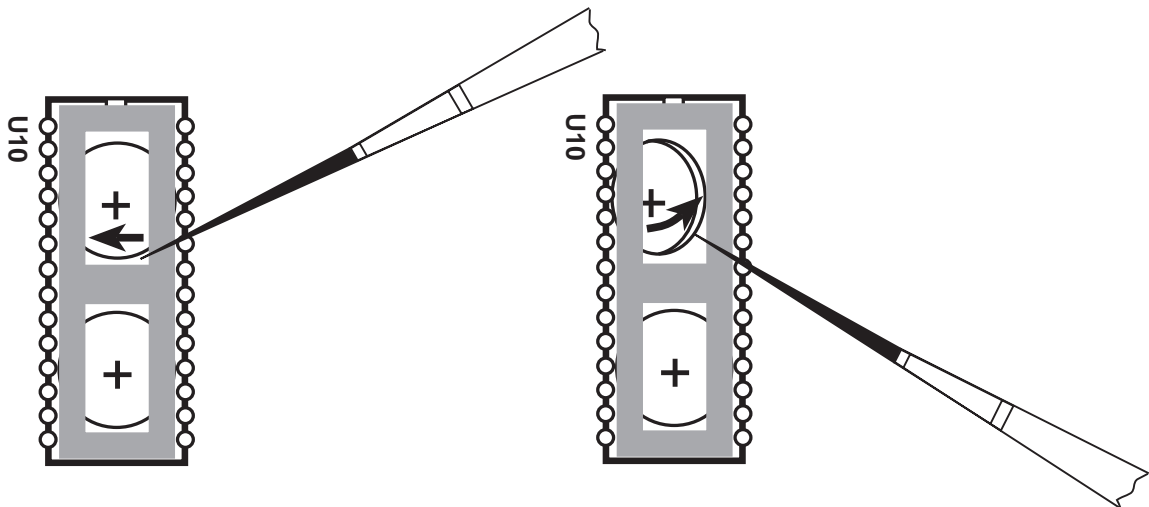

**Figure 6: AM-301-10 Backup Battery Removal**

4. Inspect the battery contacts and be sure they are clean before installing the new batteries. Clean them with alcohol and a cotton swab, if necessary.
5. Insert the edge of the new battery down through the square hole and under the left side of the plastic top. Be sure to install the new batteries with the positive (+) side up.
6. Use your finger to slide the battery to the left and down, until the right edge of the battery slips under the right side of the plastic top. Release the battery and it should spring to the right, securing itself under the holder's top piece.

### Restoring Your CMOS Settings

Besides the time and date, the AM-301-10's batteries maintain the boot routine data stored in its on-board CMOS chip. Therefore, when you remove and replace the batteries, your CMOS settings will be lost. After you install the new batteries and turn system power on, you need to access the CMOS Configuration menu and restore your settings. Refer to the *AM-6060 Owner's Manual* for detailed instructions.

If you do not use the CMOS configuration menu to restore your settings, the system will drop into a standard default boot routine: it will look first for a warm-boot streamer tape on SCSI device ID 3, then for AMOS32.MON and AMOS32.INI on SCSI disk drive 0.

Once the system is up and running, log to OPR: and enter the current time and date. Reboot the system to initialize the system up time.

### SSD and PROM Chip Removal

The type of socket used for the boot PROM and SSD chips in your AM-6060 requires a special tool for chip removal. If you ever need to remove and replace either of these chips, be sure to use the correct tool, as shown in Figure 7.

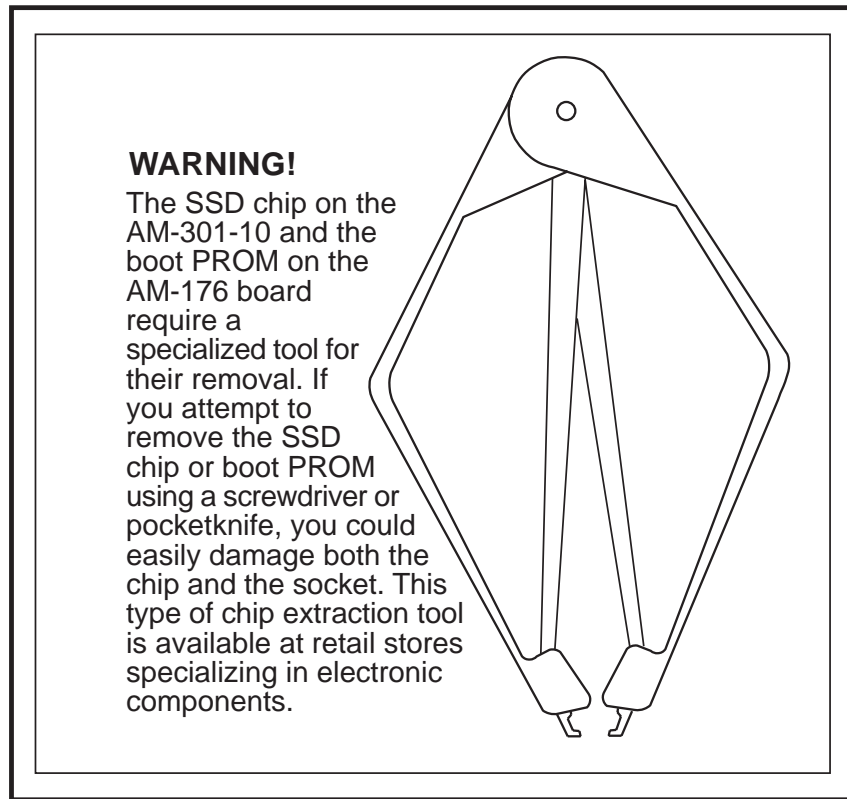

Figure 7: SSD Chip Removal Tools

### AM-966-10 CONNECTIONS

The AM-6060 uses the AM-966-10 front panel display board, which connects to the AM-301-10. In most cases, you should not need to connect any wires to or disconnect any wires from the AM-966. However, if any of your front panel display lights stop working, or if one or more wires come loose from the AM-966, you can refer to the picture and list below to check and, if necessary, remake any connections.

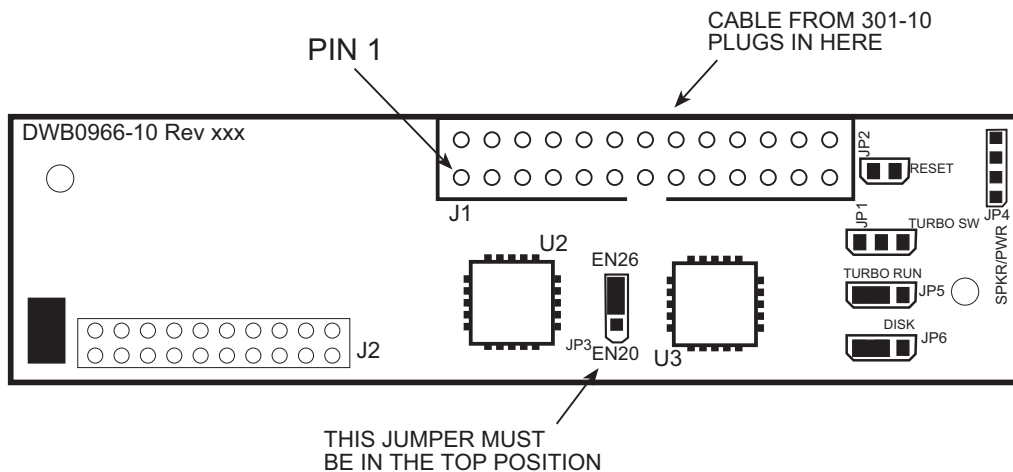

Figure 8: AM-966-10 Board Layout

The AM-966-10 board uses the following connections and jumpers:

Location	Description	Wire Order*
J1	26-pin cable to AM-301-10. Notice pin 1 orientation on Figure 8.	
JP1	Connects to Turbo switch.	Black-yellow-white
JP2	Connects to Reset switch.	Green-black or black-green
JP3	In an AM-6060, this jumper must be on the upper two pins (those closest to J1).	
JP4	To speaker and front panel power.	Red-black
JP5	Connects to system activity (Turbo) light. Place connector on left two pins (white goes on center pin).	Yellow-white
JP6	Connects to disk activity (H.D.D.) light. Place connector on left two pins (white goes on center pin).	Red-white

- \* Wires should be in this order, from top to bottom or left to right, depending on jumper orientation. In some cases, wires may be reversed; if connection doesn't work in this orientation, try reversing the connector.



If all front panel lights stop working, check the JP4 connection first. If it is loose, none of the lights will work.

## UPGRADING AM-6060 ON-BOARD MEMORY

The AM-176 has four on-board SIMM (single inline memory module) expansion slots, which support 60ns DRAMs. It also has one on-board cache SIMM. Should you want to replace or upgrade any of these SIMMs, first remove the existing SIMMs, then install new ones, following the procedures below.



If you change the amount of memory in your AM-6060, you must also reset the JP4 jumpers (memory size select) according to the settings later in this chapter.

## Removing Memory SIMMs

To remove a SIMM from its connector:

1. Power down the computer.
2. Remove the computer's cover.
3. Press out on the retainer clips and gently tilt the top of the SIMM module, so it is free of the retainer clips.
4. Lift the SIMM out of the connector.

## Installing the External Cache SIMM



The external cache SIMM must only be installed in the J1 slot, labeled CACHE SIMM. Never install memory expansion SIMMs in J1, or the cache SIMM at any other location.

To install the 64KB external cache SIMM (PDB-00701-00) on the AM-176 board:

1. Align pin 1 on the external cache SIMM module with pin 1 on connector at J1. Pin 1 on the SIMM module is on the notched end of the module (see Figure 9 below).
2. Insert the cache SIMM module into the J1 connector at a slight angle.
3. Rotate into the upright position.

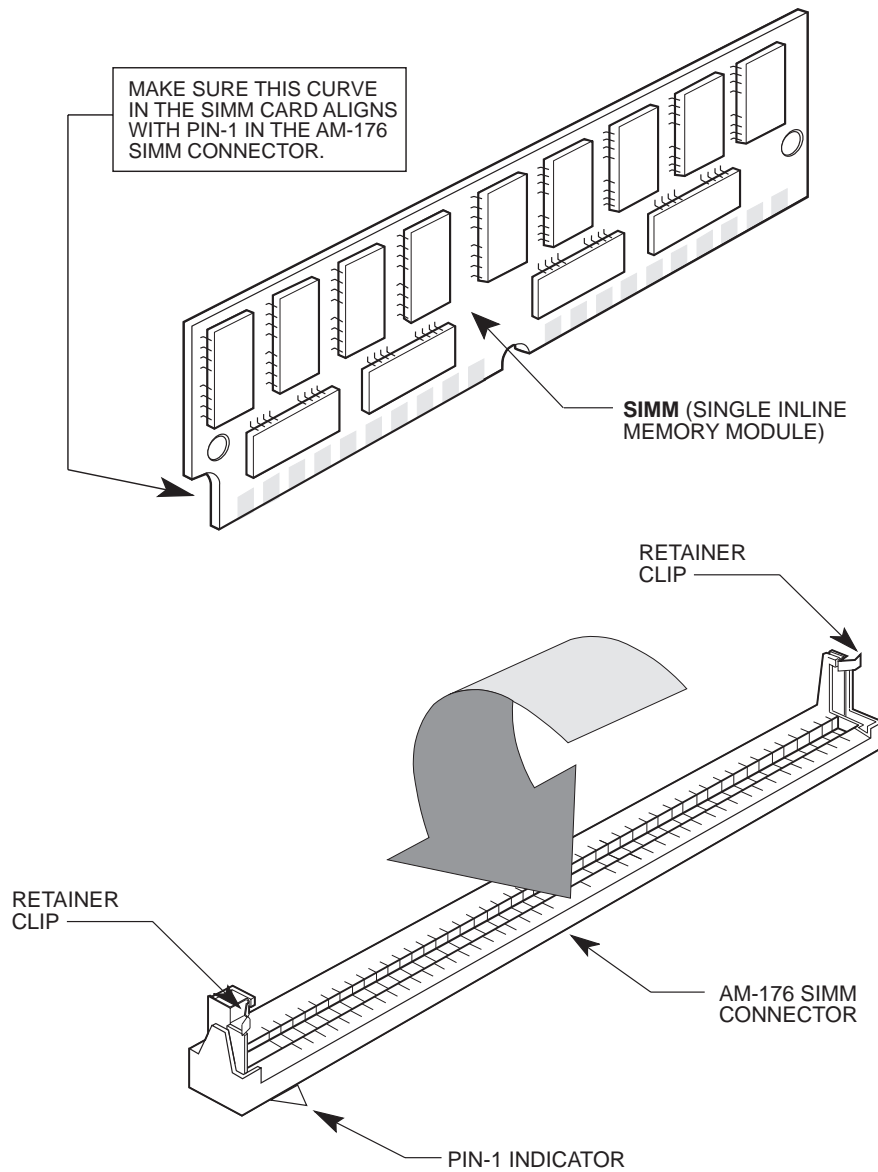

**Figure 9: AM-176 SIMM Module Installation**

The cache SIMM will engage the retainer clips and click into position, locking in place. When properly installed, the components on the cache SIMM module will be facing in toward the other memory SIMMs.

## Installing Memory SIMMs

The AM-6060 supports a minimum of 8MB and a maximum of 512MB of main memory. Memory is implemented as paired SIMM modules (of equal capacity) of 4MB, 8MB, 16MB, 32MB, 64MB, or 128MB each. Use 60ns SIMMs only; **70ns SIMMs will not work**. The following table shows the allowable memory SIMM configurations (above 256MB, only some configurations are shown—others are possible):

For this amount of memory...	Install these memory SIMMs...					
	4MB	8MB	16MB	32MB	64MB	128MB
8MB	2	--	--	--	--	--
16MB	4	--	--	--	--	--
16MB	--	2	--	--	--	--
24MB	2	2	--	--	--	--
32MB	--	4	--	--	--	--
32MB	--	--	2	--	--	--
40MB	2	--	2	--	--	--
48MB	--	2	2	--	--	--
64MB	--	--	4	--	--	--
64MB	--	--	--	2	--	--
72MB	2	--	--	2	--	--
80MB	--	2	--	2	--	--
96MB	--	--	2	2	--	--
128MB	--	--	--	4	--	--
128MB	--	--	--	--	2	--
136MB	2	--	--	--	2	--
144MB	--	2	--	--	2	--
160MB	--	--	2	--	2	--
192MB	--	--	--	2	2	--
256MB	--	--	--	--	4	--
256MB	--	--	--	--	--	2
320MB	--	--	--	2	--	2
384MB	--	--	--	--	2	2
512MB	--	--	--	--	--	4

*Table 1: AM-6060 Memory Configuration*

To install memory expansion SIMMs on the AM-176 board, use this procedure:

1. Memory SIMMs must be installed in pairs of equal capacity.
2. Always install the SIMMs of largest capacity first.
3. Always install the first pair of SIMM modules at Bank0. Use Bank1 for a second pair of SIMM modules.
4. Insert the first SIMM in connector J2. Align pin 1 at the notched end of the SIMM module with pin 1 on the connector, as shown in Figure 9.
5. Insert the SIMM module into the connector at a slight angle.
6. Rotate into the upright position.

The SIMM will engage the retainer clips and click into position, locking the SIMM in place.

7. Repeat steps 4 through 6 for the second SIMM, at connector J4. If you are using a second pair of SIMMs, insert them into J3 and J5 using the same procedure.

## Setting Memory Jumpers

After installing the SIMMs, set the jumpers at location JP4 on the AM-176 board according to Table 2, below. Again, only some configurations above 256MB are shown. As you turn on the computer, AMOS will automatically make the memory available. See Figure 5 for the location of the JP4 jumpers.

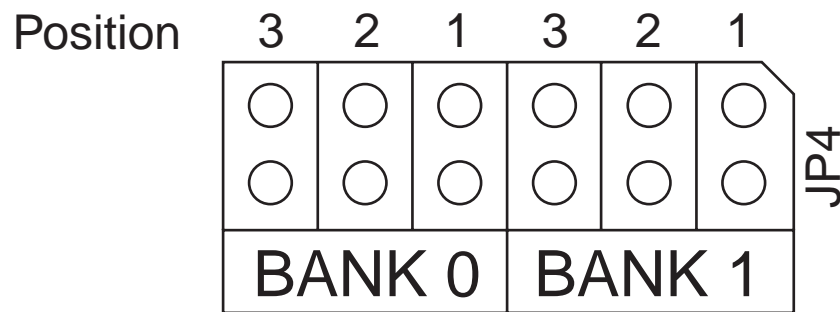

*Figure 10: JP4 Memory Jumpers*

<i>Memory Module Size Combinations:</i>	<i>Total Memory</i>	<i>Bank0 Settings Position:</i>			<i>Bank1 Settings Position:</i>		
		<i>3</i>	<i>2</i>	<i>1</i>	<i>3</i>	<i>2</i>	<i>1</i>
2 x 4MB	8MB	X	X	X	O	O	O
4 x 4MB	16MB	X	X	X	X	X	X
2 x 8 MB	16 MB	X	X	O	O	O	O
2 x 8MB + 2 x 4MB	24MB	X	X	O	X	X	X
4 x 8MB	32MB	X	X	O	X	X	O
2 x 16MB	32MB	X	O	X	O	O	O
2 x 16MB + 2 x 4MB	40MB	X	O	X	X	X	X
2 x 16MB + 2 x 8MB	48MB	X	O	X	X	X	O
4 x 16MB	64MB	X	O	X	X	O	X
2 x 32MB	64MB	X	O	O	O	O	O
2 x 32MB + 2 x 4MB	72MB	X	O	O	X	X	X
2 x 32MB + 2 x 8MB	80MB	X	O	O	X	X	O
2 x 32MB + 2 x 16MB	96MB	X	O	O	X	O	X
4 x 32MB	128MB	X	O	O	X	O	O
2 x 64MB	128MB	O	X	X	O	O	O
2 x 64MB + 2 x 4MB	136MB	O	X	X	X	X	X
2 x 64MB + 2 x 8MB	144MB	O	X	X	X	X	O
2 x 64MB + 2 x 16MB	160MB	O	X	X	X	O	X
2 x 64MB + 2 x 32MB	192MB	O	X	X	X	O	O
4 x 64MB	256MB	O	X	X	O	X	X
2 x 128MB	256MB	O	X	O	O	O	O
2 x 128MB + 2 x 32MB	320MB	O	X	O	X	O	O
2 x 128MB + 2 x 64MB	384MB	O	X	O	O	X	X
4 x 128MB	512MB	O	X	O	O	X	O

**Key to settings: X = Installed, O = Open**

*Table 2: AM-176 Memory Module Jumper (JP4) Settings*

## PERIPHERAL MOUNTING

Your AM-6060 computer can hold six half-height peripherals, in three 3.5" and three 5.25" mounting bays. One of the 3.5" bays and all of the 5.25" bays are accessible through the computer's front panel after you remove the appropriate filler panels.



3.5" hard disk drives can be mounted in the 5.25" bays using special mounting brackets.

The following figure shows all six peripheral mounting positions.

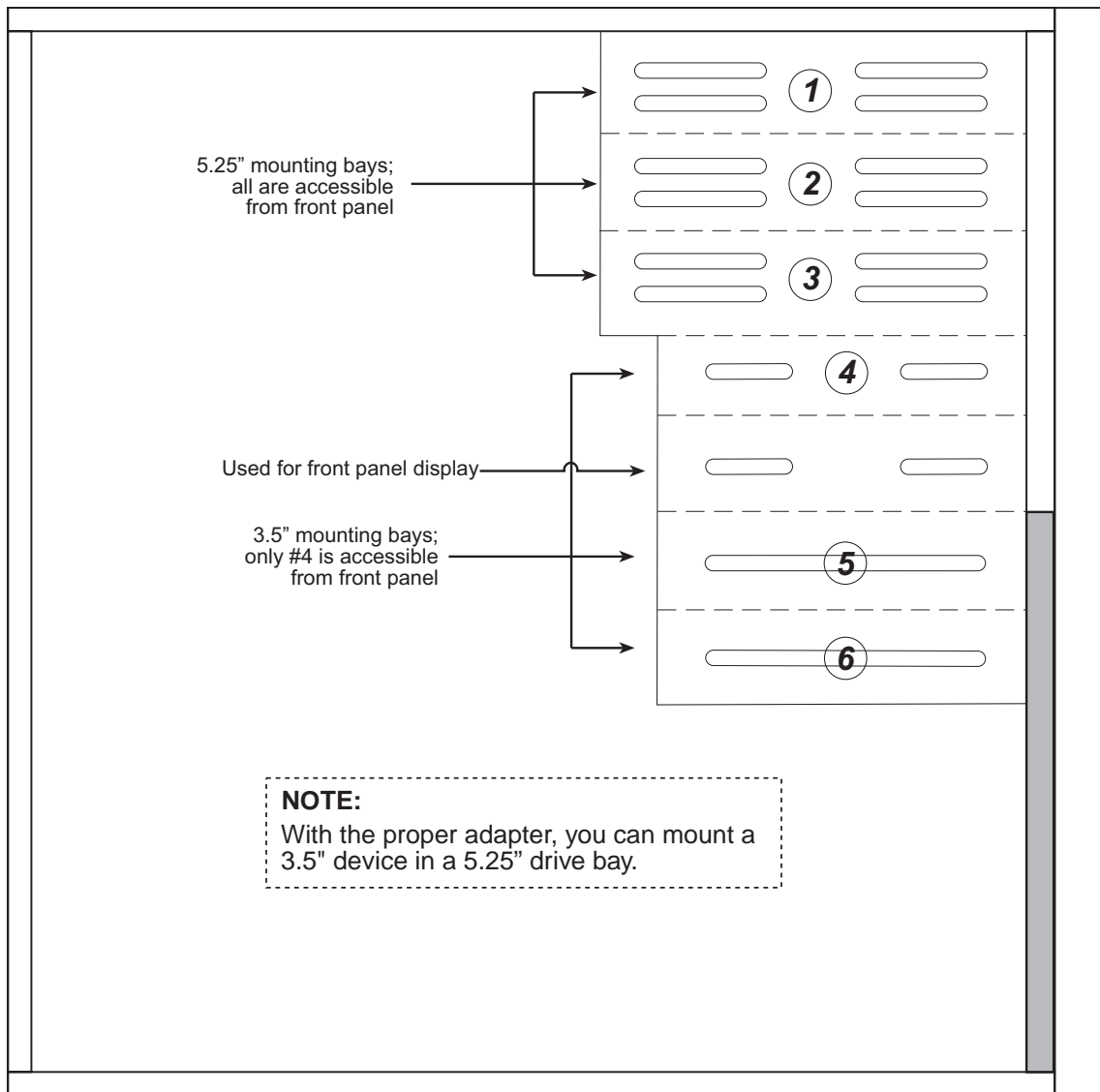

*Figure 11: Peripheral Bay Positions*



The following paragraphs give general instructions for mounting peripherals in the AM-6060 cabinet. For detailed instructions on configuring a particular device, see the installation instructions shipped with that device.

A peripheral is installed in a drive bay using four Phillips-head screws. To install the screws, you need access to both sides of the drive bay. On one side of the cabinet, all six of the bays are easily accessible. However, on the other side, a metal stabilizing panel blocks access to all but the top two bays. To ease the installation process, Alpha Micro installs peripherals starting at the top and working down. If your computer includes one disk drive and one tape drive, the two peripherals will be in bays 1 and 2, which are easily accessible from both sides of the chassis.

To install peripherals in bays 3 through 6, you need to remove the metal panel from the right side of the chassis (looking from the front). To install peripherals in these locations:

1. Remove the two Phillips-head screws attaching the panel to the chassis.  
Notice how the panel is positioned over the two alignment tabs on the bottom of the chassis. When you reinstall the panel, you must make sure it is properly positioned over both tabs; if not, you won't be able to reinstall the two screws.
2. Tilt the top of the panel away from the chassis and remove it.
3. With the side panel out of the way, you can access both sides of the peripheral mounting bracket and have complete access to all six drive bays.
4. To install a peripheral, simply slide it into one of the available bays and install the four screws (two on each side) that hold the device in place.
5. Don't forget to attach the appropriate power and interface cables to your new peripheral.
6. After you have completed your peripheral installation, you can reinstall the side metal panel.



The metal panel is an integral part of the chassis assembly. With it removed, the chassis may shift slightly, either forward or backward. To reinstall the panel, you can realign the chassis by placing one hand on the top of the chassis and applying pressure either forward or backward. With the chassis properly aligned, the panel will slide into place.

## ADDITIONAL DOCUMENTATION

Each peripheral device sold by Alpha Micro is covered by its own set of installation instructions. The installation instructions include information on jumper settings, termination, and cabling. Before installing a peripheral, make sure you read the documentation pertaining to the device.

If the documentation was not included with your peripheral device, it is probably contained on the AlphaCD which is distributed to all Alpha Micro Value Added Resellers on a quarterly basis, and on our Web site at [www.amos-online.com](http://www.amos-online.com).